

Operating Instructions for:



Electric Motor Powered Pumps
Gas Engine Powered Pumps
Rotary Air Motor Powered Pumps

(As listed in EC Declaration)

HYDRAULIC PUMP

Max. Capacity: See Pump Data Plate

Pump	kw	dB(A) at Idle and 700 Bar
PE8 Series	.37	67/81
PE17 Series	.37	67/81
PA17 Series	1.12	85/90
PE30 Series	.74	87/82
PG30 Series	1.49	84/96
PE46 Series	1.12	77/81
PA46 Series	2.24	85/90
PE55 Series	.84	87/86
PA55 Series	2.24	87/88
PG55 Series	2.98	75/87
PR10 Series	.19	65/72
PG18 Series	1.86	81/96
PG120 Series	4.1	85/95
PQ120 Series	2.24	73/78
PG400 Series	14.9	N/A
66262	2.24	N/A

Definition: A hydraulic pump delivers hydraulic fluid under pressure through the use of compressed air, an electric motor, or a gas engine as a power source.

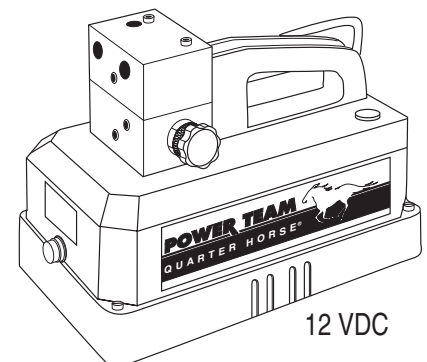
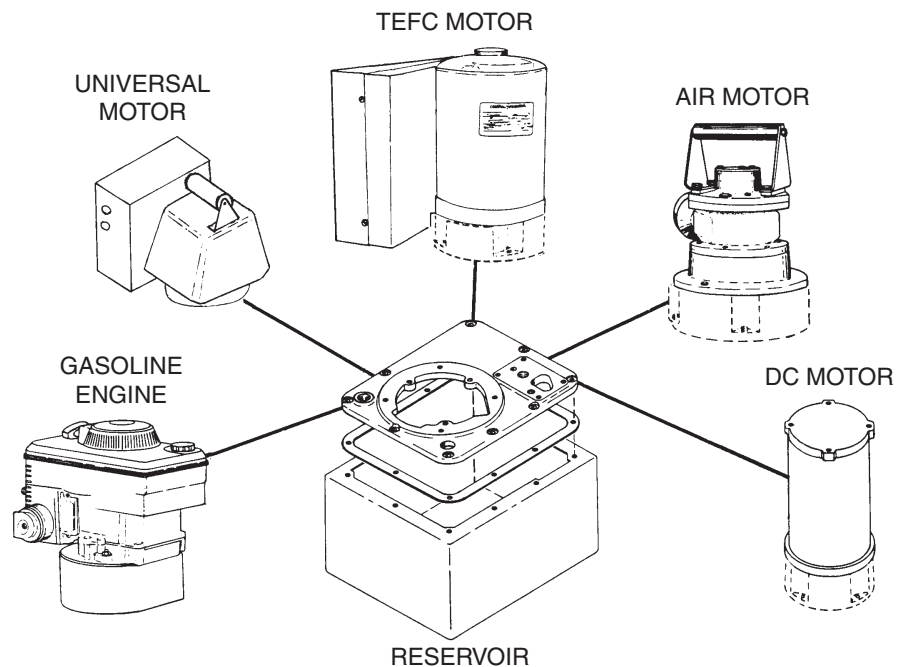

NOTE:

- For a detailed parts list or to locate a Power Team Authorized Hydraulic Service Center, contact your nearest Power Team facility. A list of all Power Team facilities is located at the end of this document.
- Carefully inspect the pump upon arrival. The carrier, not the manufacturer, is responsible for any damage resulting from shipment.
- The customer can choose from a variety of motors, controls, reservoirs, and other options. These instructions will include directions for options that your particular pump may not have.
- Do not change motors without consulting the pump manufacturer's Technical Services Department.

SAFETY DEFINITIONS

Safety symbols are used to identify any action or lack of action that can cause personal injury. Your reading and understanding of these safety symbols is very important.

 **DANGER** - Danger is used only when your action or lack of action will cause serious human injury or death.

 **WARNING** - Warning is used to describe any action or lack of action where a serious injury can occur.

 **DANGEROUS VOLTAGE** - Dangerous voltage is used to describe any action or lack of action that could cause serious personal injury or death from high voltage electricity.

IMPORTANT - Important is used when action or lack of action can cause equipment failure, either immediate or over a long period of time.

SAFETY PRECAUTIONS



These instructions are intended for end-user application needs. Many problems with new equipment are caused by improper operation or installation. For a detailed parts list or to locate a Power Team Authorized Hydraulic Service Center contact your nearest Power Team facility. A list of all Power Team facilities is located at the end of this document.

 **WARNING:** It is the operator's responsibility to read and understand the following safety statements,

- Only qualified operators should install, operate, adjust, maintain, clean, repair, or transport this machinery.
- These components are designed for general use in normal environments. These components are not specifically designed for lifting and moving people, agri-food machinery, certain types of mobile machinery or special work environments such as: explosive, flammable or corrosive. Only the user can decide the suitability of this machinery in these conditions or extreme environments. Power Team will supply information necessary to help make these decisions.

 **WARNING:** To help prevent personal injury,

GENERAL

-  Always wear eye protection whenever operating hydraulic equipment.
-  Always wear hearing protection as required. Refer to the sound level (dB[A]) chart.
- Operation, repair, or maintenance of hydraulic equipment should be performed by a qualified person who understands the proper function of hydraulic equipment per local directives and standards.
- Hydraulic equipment must be assembled correctly and then checked for proper function before use. Use hydraulic components of the same hydraulic pressure ratings. An appropriate hydraulic pressure gauge is recommended to monitor pressure.
-  Never place your hands or other body parts near a hydraulic fluid leak. Never use your hands or other body parts to check for a possible leak. High pressure fluid can be injected under your skin causing serious injury and/or infection.

SAFETY PRECAUTIONS (GENERAL) CONTINUED -

- High pressure fluid is present throughout a hydraulic system. Always use caution when operating, repairing, or maintaining this equipment. Before beginning any work on any hydraulic system component, stop the equipment, disconnect from its power source, and relieve all pressure in all parts of the system. Do not tamper with the internal hydraulic relief valve settings.
- Avoid exposing hydraulic equipment (especially hoses) to extreme high or low temperatures. Damage to equipment or failure may result and cause loss of control or injury to the operator.
-  Exercise caution to avoid the risk of fire.
- Do not drop any hydraulic system components. Damage to the equipment and/or injury may result.
- Avoid slipping or falling by cleaning up any oil spills.
- Avoid back injury by always lifting equipment carefully.
- It is strongly recommended to view the Power Team Hydraulic Safety video tape before using hydraulic equipment.

POWER SUPPLY**Electric****Electrical Shock or Electrocution**

- Any electrical work must be done and tested by a qualified electrician per local directives and standards.
- Disconnect the pump from the power supply and relieve pressure before removing the motor case cover or performing maintenance or repair.
- Never use an ungrounded power supply with this unit.
- If the power cord is damaged or wiring is exposed, replace or repair immediately.
- Changing the voltage on this unit is an involved, and if improperly performed, hazardous procedure. Consult the manufacturer for specific information before attempting any rewiring.
- All PE55 Series pump motors must be wired for clockwise (CW) rotation when viewed from the lead end (top) of the motor. PE8 Series, PE17 Series, PE30 Series, PR10 Series, and PE46 Series pump motors must be wired for counterclockwise (CCW) rotation when viewed from the lead end (top) of the motor.
- Check the *total* amperage draw for the electrical circuit you will be using. (For example: Do not plug a pump or pumps that may draw 25 amps into a 20 amp fused electrical circuit.)
- Do not attempt to increase the powerline capacity by replacing a fuse with another fuse of higher value. Overheating of the powerline and the possibility of a fire will result.
- To rewire a motor from one voltage to another or when a flow control valve is changed between manual and solenoid, consult the electrical schematic in the pump's parts list.
- Electric pumps should never be exposed to rain or water which could cause personal electrical hazard.
- Avoid conditions which can cause damage to the power cord such as abrasion, crushing, sharp cutting edges, or corrosive environment. Damage to the power cord can cause an electrical hazard.

Gasoline Engine**No Smoking No Open Flame Flammable**

- Read the instruction manual for the gasoline engine before using for correct operating procedure.
- Turn off the engine and relieve pressure when not in use or when working on any part of the system.
- Proper ventilation is critical during refueling.
- Do not allow fuel to splash on the engine when refueling.
- Do not add fuel when the engine is running or hot.

SAFETY PRECAUTIONS (POWER SUPPLY) CONTINUED -

Air Driven Motor

- A quick disconnect must be installed in the air line to the pump.
- Disconnect air supply and relieve pressure when pump is not in use or when breaking any connection in the hydraulic system.
- Control circuit must comply with local directives and standards.

HYDRAULIC HOSES AND FLUID TRANSMISSION LINES

- Avoid straight line tubing connections in short runs. Straight line runs do not provide for expansion and contraction due to pressure and/or temperature changes. See diagrams in “Set-up Instructions” section of this form.
- Eliminate stress in the tube lines. Long tubing runs should be supported by brackets or clips. Tubes through bulkheads must have bulkhead fittings. This makes easy removal possible and helps support the tubing.
- Before operating the pump, all hose connections must be tightened with the proper tools. Do not overtighten. Connections should only be tightened securely and leak-free. Overtightening can cause premature thread failure or high pressure fittings to split at pressures lower than their rated capacities.
- Should a hydraulic hose ever rupture, burst, or need to be disconnected, immediately shut off the pump and release all pressure. Never attempt to grasp a leaking pressurized hose with your hands. The force of escaping hydraulic fluid could cause serious injury.
- Do not subject the hose to potential hazard such as fire, sharp surfaces, extreme heat or cold, or heavy impact. Do not allow the hose to kink, twist, curl, crush, cut, or bend so tightly that the fluid flow within the hose is blocked or reduced. Periodically inspect the hose for wear, because any of these conditions can damage the hose and possibly result in personal injury. Never repair with tape.
- Do not use the hose to move attached equipment. Stress can damage the hose and possibly cause personal injury.
- Hose material and coupler seals must be compatible with the hydraulic fluid used. Hoses also must not come in contact with corrosive materials such as creosote-impregnated objects and some paints. Hose deterioration due to corrosive materials can result in personal injury. Consult the manufacturer before painting a hose. Never paint a coupler.

PUMP

- Do not exceed the hydraulic pressure rating noted on the pump nameplate or tamper with the internal high pressure relief valve. Creating pressure beyond rated capacities can result in personal injury.
- Before replenishing the fluid level, retract the system to prevent overfilling the pump reservoir or bladder. An overfill can cause personal injury due to excess reservoir or bladder pressure created when the cylinders are retracted.
- Always shut off the motor or engine and relieve pressure before breaking any connections in the system.
- The motor or engine is the major part of the weight of the pump. Always take this into consideration when lifting or moving the pump.

CYLINDER

- Do not exceed the rated capacities of the cylinders. Excess pressure can result in personal injury.
- Do not set poorly balanced or off-center loads on a cylinder. The load can tip and cause personal injury.
- Read and understand the cylinder operating instructions and warning decals before using the cylinder.



DANGER: A double-acting cylinder or ram must have both hoses and all couplers securely connected to both ports. If one of the two ports is restricted or becomes disconnected, pressure will build and the cylinder, hose or coupler can burst, possibly causing serious injury or death.

HYDRAULIC FLUIDS

- Properly dispose of all fluids, components, and assemblies at the end of their useful life.
- Hydraulic fluid should be compatible with all hydraulic components.

SET-UP INSTRUCTIONS

Filling The Pump Reservoir Or Bladder

NOTE: Most pumps are shipped without hydraulic fluid in the reservoir. Hydraulic fluid may have been shipped with the pump in a separate container. If hydraulic fluid is needed, use 215 SSU @ 100° F (47 cSt @ 38° C) hydraulic fluid. Pumps with a bladder are shipped with hydraulic fluid in the bladder.

1. Clean the area around the filler cap to remove all dust and grit. Any dirt or dust in the hydraulic fluid can damage the polished surfaces and precision-fit components of this pump.
2. Retract all cylinder(s) to their return position.
3. Remove the filler cap and insert a clean funnel with a filter. Fill the reservoir with hydraulic fluid to 1" (25,4 mm) (PE8, PE17 & PE30 series pumps to 1-1/2" [38,1 mm]) from the cover plate. PR10 series pump bladder must be filled completely. Replace the filler cap. **IMPORTANT: For PR10 series pumps, tighten filler cap 1/2 - 1 turn after o-ring contacts sealing surface. Overtightening can cause pump damage on bladder equipped pumps.**

Hydraulic Connections

Remove the thread protectors or dust covers from the hydraulic ports if applicable. Clean the areas around the fluid ports of the pump and cylinder. Inspect all threads and fittings for signs of wear or damage, and replace as needed. Clean all hose ends, couplers and union ends. Connect all hose assemblies to the pump and cylinder. Use an approved, high-grade pipe thread sealant to seal all hydraulic connections. Tighten securely and leak-free but do not overtighten.

Hydraulic lines and fittings can act as restrictors as the cylinder or ram retracts. The restricting or slowing of the fluid flow causes back pressure that slows the cylinder's or ram's return. Return speed also varies because of the application, condition of the cylinder or ram, inside diameter of hose or fitting, length of the hose, and the temperature and viscosity of the hydraulic fluid.

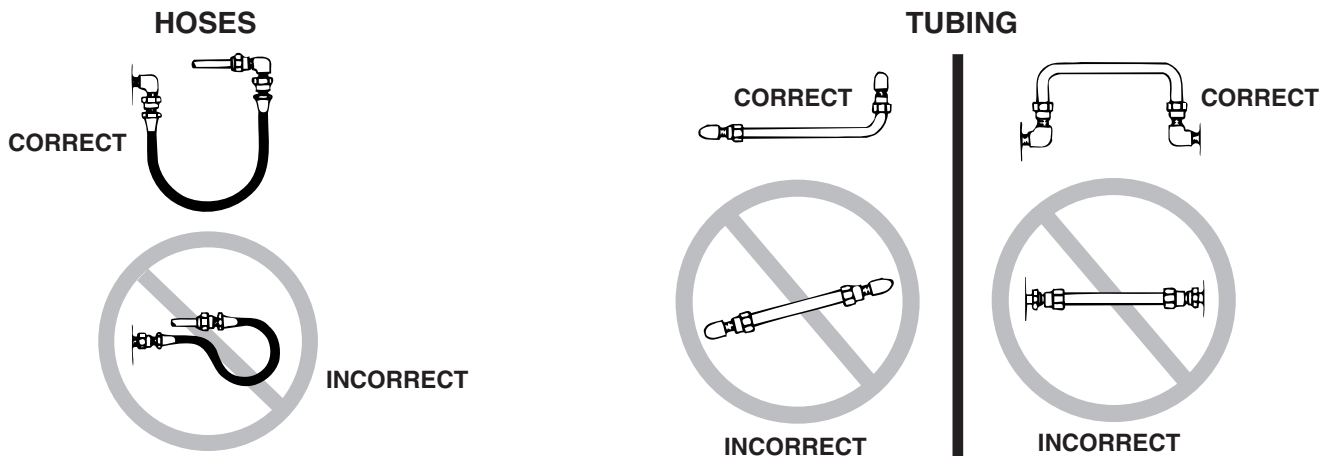

Bleeding The System

After all connections are made, the hydraulic system must be bled of any trapped air. Refer to the diagrams below.

With no load on the system and the pump vented and positioned higher than the cylinder or ram, cycle the system several times. Check the reservoir for possible low fluid level and fill to proper level with approved, compatible hydraulic fluid as necessary (see "Filling The Pump Reservoir Or Bladder" section under Set-up Instructions).

IMPORTANT: Some spring return cylinders or rams have a cavity in the rod which forms an air pocket. This type of cylinder or ram should be bled when positioned upside down or lying on its side with the port facing upward.

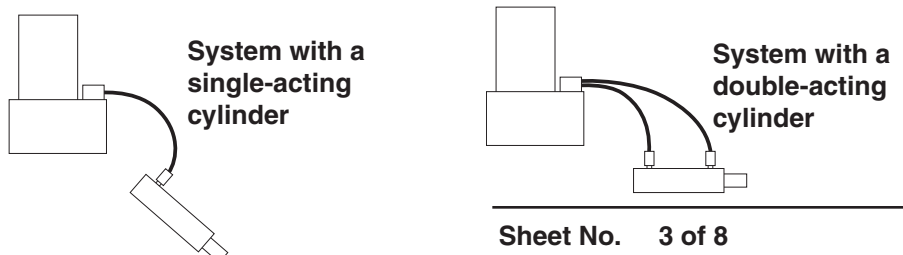

PUMP OPERATION

When operating the pump for the first time:

1. Valve and hose connections must be tight, and the reservoir or bladder must be filled to the proper fluid level. Start the motor.
2. Jog the pump several times to build pressure.
3. Run cylinder out to its full travel several times to eliminate air from the system. For more complete instructions, refer to the section titled "Bleeding The System" under Set-up Instructions.
4. With the cylinder(s) retracted completely, check the fluid level in the reservoir or bladder and add fluid if necessary. Refer to "Filling The Pump Reservoir Or Bladder" under Set-up Instructions.
5. The pump is now ready to be put into regular operation.



DANGER: When lifting or lowering a load, the load must be under operator control at all times and others must be clear of the load. Use blocking and cribbing to guard against a falling load. Do not drop the load. The use of a load lowering or metering valve is recommended in addition to the pump directional control valve.

ELECTRIC PUMP

Universal Motor: The universal motor is wired for 115 or 230 volts, 50/60 cycles according to the customer's request. **This motor cannot be rewired.**

TEFC and DC Motors: See pump data plate for voltage, frequency, current, and power specifications. If rewired, retesting may be required per local directives and standards. PR10 series pump voltage is 12 VDC and is not changeable.

1. Place the valve in neutral position.
2. Plug in the pump.
3. Start the pump and shift as required.
4. Turn the pump off when not in use.

Note: For specific function of your pump see the "Valve Options" section of this form.

IMPORTANT:

- **Correct voltage is required for the pump to operate properly.**
 - **Low voltage may cause: overheated motor; motor fails to start under load; motor surging when trying to start; or motor stalls before maximum pressure is reached.**
 - **Check the voltage rating on the pump motor name plate to be certain the outlet or power source you are using is of the proper voltage.**
 - **Always check the voltage at the motor with the pump running at full pressure.**
- **Never run the motor on long, light gauge extension cords. Refer to the minimum recommended gauge chart below.**

AMPS At Maximum Hyd. Pressure	Electrical Cord Size AWG (mm ²) 3.2 Volt Drop			
	Length of Electrical Cord			
	0-25 ft. (0-8 m)	25-50 ft. (8-15 m)	50-100 ft. (15-30 m)	100-150 ft. (30-46 m)
6	18 (.82)	16 (1.33)	14 (2.09)	12 (3.32)
10	18 (.82)	14 (2.09)	12 (3.32)	10 (5.37)
14	16 (1.33)	12 (3.32)	10 (5.37)	8 (8.37)
18	14 (2.09)	12 (3.32)	8 (8.37)	8 (8.37)
22	14 (2.09)	10 (5.37)	8 (8.37)	6 (13.30)
26	12 (3.32)	10 (5.37)	8 (8.37)	6 (13.30)
30	12 (3.32)	10 (5.37)	6 (13.30)	4 (21.29)

PUMP OPERATION CONTINUED -

GAS PUMP

Gasoline-Powered: Consult the instruction manual for the gasoline engine to determine its specifications.

1. Place the valve in the neutral or hold position.
2. Start the gas engine according to the operating instruction manual provided.
3. When the engine is running properly, shift the valve as necessary.
4. Turn the pump off when not in use.

AIR PUMP

Rotary Air Motor: Remove the thread protectors from the air inlet, and install the air supply fittings (not supplied) as shown in Figure 1. Air supply must be minimum 50 CFM (1,4 M³/min.) and 80 PSI (5,5 BAR), with 100 PSI (7 BAR) maximum.

1. Place the valve in the neutral or hold position.
2. Couple the air pump to the air supply and turn on the supply valve (if provided).
3. Open (or turn on) the air supply control valve at the pump (hold-to-run hand control is provided).
4. Shift the pump as necessary.
5. Turn the pump off when not in use.
6. Use of an air filter/lubricator is recommended.

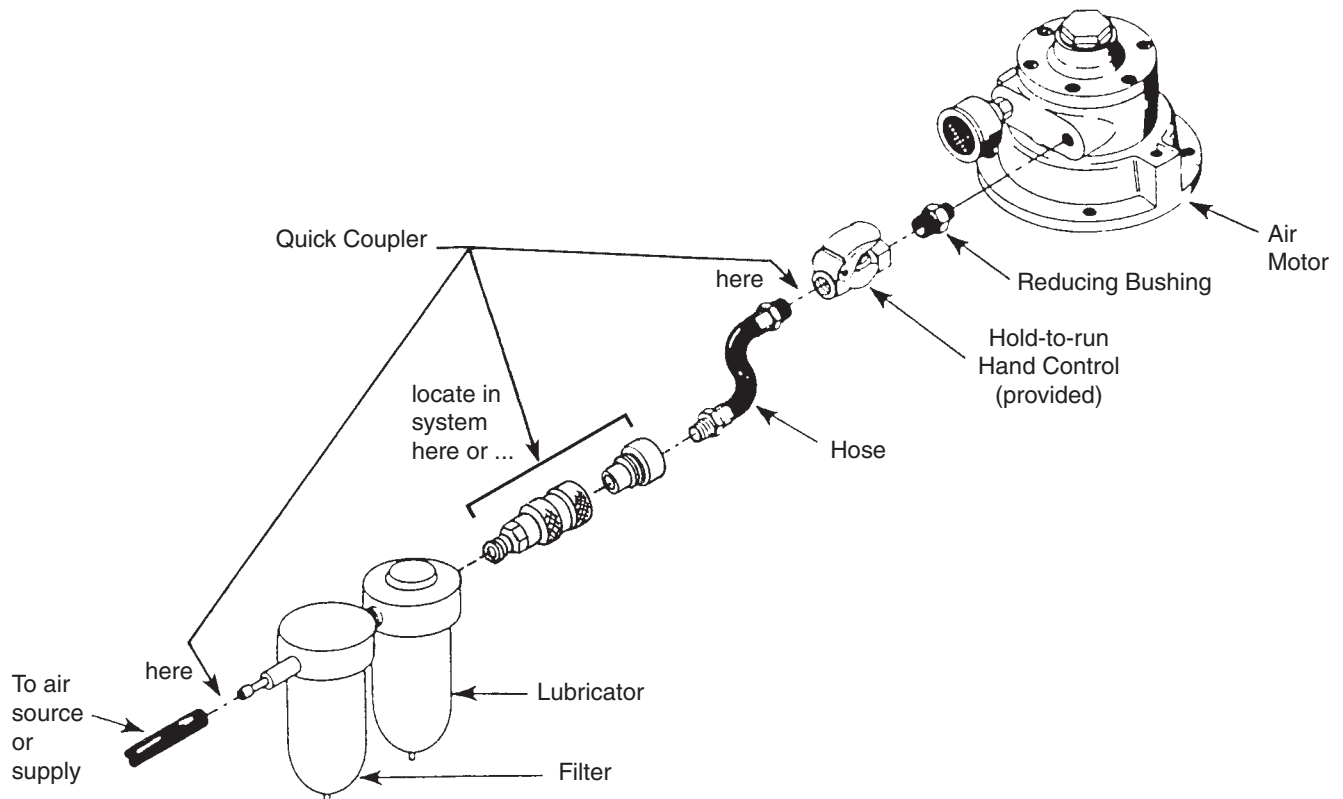

**Figure 1
Recommended Air Line Hook-up**

DIRECTIONAL CONTROL VALVE OPTIONS

- NOTE:**
- Some valves return fluid to the reservoir or bladder when the pump stops or when the valve is shifted. The correct valve must be used, especially when lifting a load.
 - "Hold-to-run" controls are recommended and must be used with correct valves for certain applications, especially when lifting a load.
 - Not all valves fit on all pumps.

! DANGER: When lifting or lowering a load, the load must be under operator control at all times and others must be clear of the load. Use blocking and cribbing to guard against a falling load. Do not drop the load. The use of a load lowering or metering valve is recommended in addition to the pump directional control valve.

2-Position, 2-Way Manual Valve Used With Single-acting Cylinder

1. To HOLD pressure, turn the valve control handle counterclockwise (CCW).
2. Activate the pump unit to advance the cylinder.
3. When the cylinder has advanced to the desired position, deactivate the switch or remote switch, or turn the pump unit OFF. The cylinder will HOLD pressure.
4. To retract the cylinder, turn the valve control handle clockwise (CW) slowly.

FOR PE17 SERIES (9517)

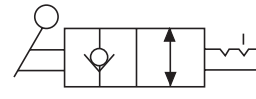

FOR PE30, PE46, AND
FOR PR10 SERIES (9561)

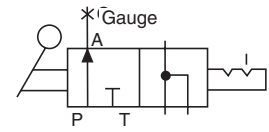

PE55 SERIES (9584)

! WARNING: Valve 9517 and 9561 work the same as a manifold if the pump is operated with the valve in the RELEASE position. In this position, the cylinder will advance when the pump is running and *retract* when the pump is stopped.

! DANGER: Never use valve 9517 and 9561 in the RELEASE position when lifting a load!

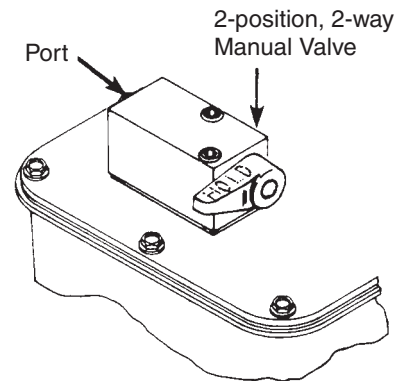
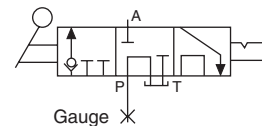

Figure 1

3-Position, 3-Way Manual Valve Used With Single-acting Cylinders

1. To hold pressure, turn the valve control handle clockwise (CW).
2. Activate the pump unit to advance the cylinder.
3. When the cylinder has advanced to the desired position, deactivate the switch or remote switch, or turn the pump unit OFF, or shift the valve to the center position. The cylinder will HOLD pressure.
4. To retract the cylinder, turn the valve control handle counterclockwise (CCW) slowly.



9520

! WARNING: When the valve is in the ADVANCE position, the cylinder will advance when the pump is running, and hold when the pump is stopped or the valve is in the CENTER position. The cylinder can be retracted by moving the valve to the RETRACT position.

VALVE OPTIONS CONTINUED -

3-Position, 4-Way Manual Valve used with Double-acting Cylinders

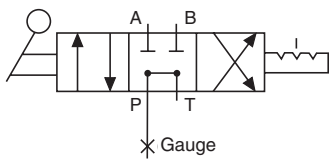

9500 (non posi-check)

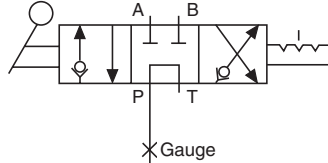

9506 (with posi-check)

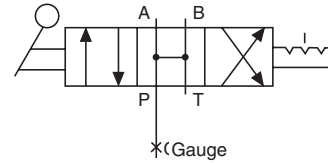

9511 (non posi-check)

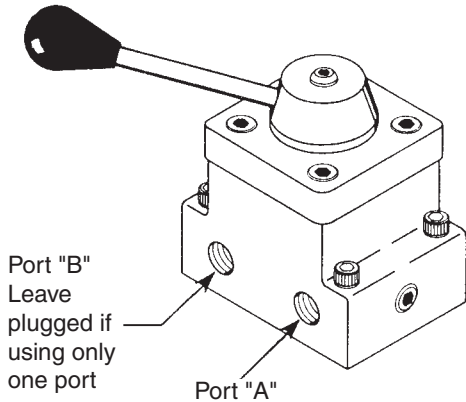

Figure 2

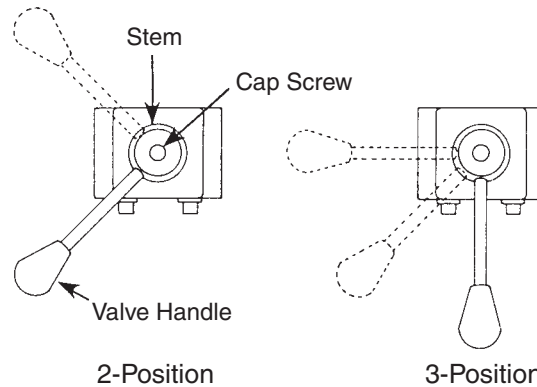

Figure 3

NOTE:

- This valve is a low torque design for use with double-acting or single-acting cylinder(s).
- If this valve is to be used as a 3-way with single-acting cylinder(s), one port (A or B) must remain plugged (use steel plug).
- Valve handle can be moved to the desired position by loosening the cap screw and rotating in increments of 22-1/2°.

1. Position the valve control lever in the NEUTRAL or HOLD position.
2. Activate the pump unit.
3. Advance the cylinder by shifting the valve control lever to the ADVANCE position.
4. When the cylinder has advanced to the desired position, turn the pump unit OFF, or shift the valve to the HOLD position.

NOTE: Non "posi-check" valves will momentarily lose pressure when shifting to HOLD position. See "posi-check" valve section of this form.

5. Retract the cylinder by shifting the valve control lever to the RETRACT position.
6. Activate the pump unit if using double-acting cylinders.

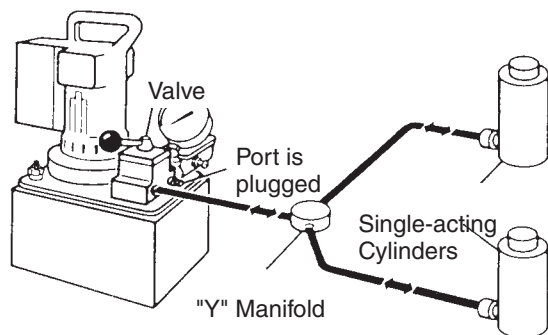

Examples of typical workholding applications:
SINGLE-ACTING CYLINDER(S) IN THE CIRCUIT
CONTROLLED BY A PUMP-MOUNTED VALVE

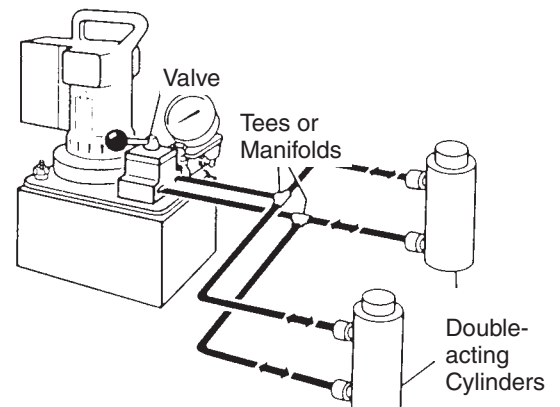

DOUBLE-ACTING CYLINDER(S) IN THE CIRCUIT
CONTROLLED BY A PUMP-MOUNTED VALVE

Other valves are available.
Consult your dealer, catalog or valve
operating instructions for details of operation.

VALVE OPTIONS CONTINUED -

"Posi-Check" Valves

If a "Posi-Check" open center valve is used, a hydraulic gauge in the gauge port shows zero pressure when the valve is switched to the neutral (hold) position. Cylinder pressure, however, is held without loss. **If reading the cylinder pressure, a gauge must be installed in the outlet port of the valve.**

To install a hydraulic gauge (refer to Figure 4):

1. Remove the pipe plug from the valve's gauge port.
2. Install a steel 45° elbow fitting.
3. Install the gauge into the 45° elbow fitting.

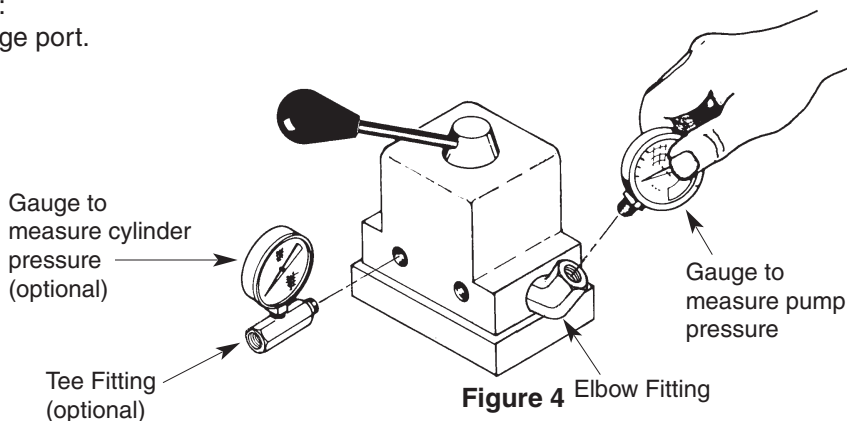
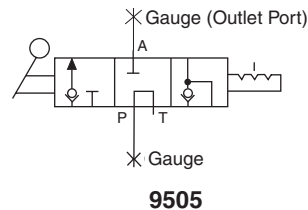

Automatic Dump Valve

1. Activate the pump unit to advance the cylinder.
2. Release the remote switch to release pressure and retract the cylinder.



DANGER: Never use this valve for lifting a load!

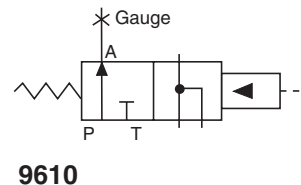

Solenoid Controlled, Pilot Operated Valve Used With Single-acting Cylinders

OPERATION

Neutral (HOLD): When neither solenoid is energized, fluid from pump is directed back to tank and fluid from cylinder is checked in the cylinder.

Advance: When solenoid "B" is energized, fluid from pump is directed through pressure port to cylinder.

Return: When solenoid "A" is energized, fluid from the pump and from the cylinder is directed back to tank.

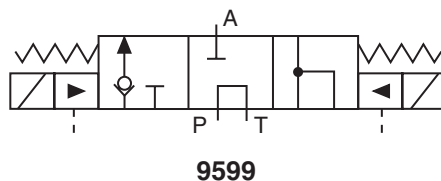

NOTE: Pressure holds without loss when shifted from cylinder port to the neutral (HOLD) position.

Solenoid Controlled, Pilot Operated Valve Used With Double-acting Cylinders

OPERATION

Neutral (HOLD): When both solenoids are de-energized, fluid from pump circulates at free flow from the pressure port "P" to tank "T". Both cylinder ports are blocked.

Solenoid "A" Energized: Pressure to cylinder port "A".
Cylinder port "B" to tank.

Solenoid "B" Energized: Pressure to cylinder port "B".
Cylinder port "A" to tank.

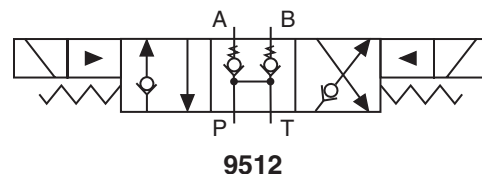

NOTE: Pressure holds without loss when shifted from cylinder port to the neutral (HOLD) position.

VALVE OPTIONS CONTINUED -

Solenoid Controlled, Air Operated Valve Used With Single- or Double-acting Cylinders

OPERATION

Position "A" (Air Port "A"): Pressure to Port "A". Port "B" to tank.

Position "B" (Air Port "B"): Pressure to Port "B". Port "A" to tank.

NOTE: All ports open to tank during transition between valve positions.

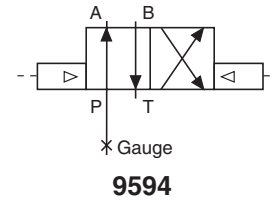

Single-acting, Spring Return Cylinder: Either fluid port "A" or "B" must be plugged with a steel plug on the valve. With port "B" plugged, the sequence of operation is as follows: When solenoid is energized to position "A", fluid port "A" becomes pressurized. When solenoid is energized to position "B", fluid port "A" becomes the return port.

Double-acting Cylinders: When operating double-acting cylinders, fluid port "A" can be connected to either the advance or return port of the cylinder and fluid port "B" will be connected to the remaining port. Sequence of operation is as follows: When solenoid is energized to position "A", port "A" becomes pressurized and extends the cylinder and fluid port "B" becomes the return port. When solenoid "B" is energized, the opposite of step 1 happens.

The application in Figure 5 represents a typical set-up using a control valve and multiple double-acting cylinders (one double-acting cylinder may be used). Interflow will occur.

If a different set-up or cylinder is being considered, contact your nearest Power Team facility.

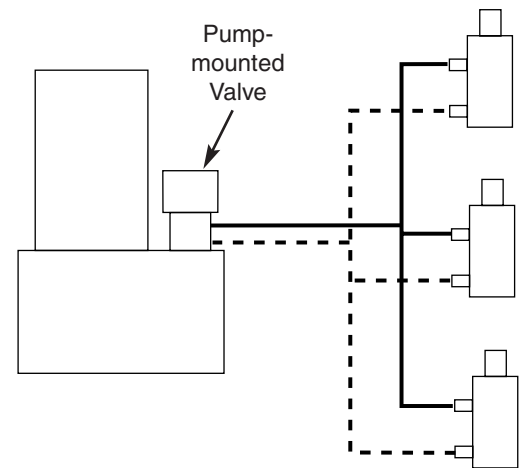

Figure

ADJUSTING THE PRESSURE REGULATING CONTROLS

The pressure regulating valve and pressure switch are shown in Figure 6. The pressure regulating valve can be adjusted to bypass fluid at a given pressure setting while the pump continues to run. The pressure switch can be adjusted to stop the pump at a given pressure setting. To ensure accuracy and low pressure differential (approx. 300 PSI [21 BAR]) throughout the pressure range (1,000 to 10,000 PSI [70 to 700 BAR] depending on the pump model), the pressure switch should be used with the pressure regulating valve. The pressure switch must be set at a pressure lower than the pressure regulating valve to work properly.

ADJUSTING THE PRESSURE REGULATING CONTROLS CONTINUED -

Adjusting The Pressure Regulating Valve

NOTE: For easy adjustment of the pressure regulating valve, always adjust the pressure by *increasing* to the desired pressure setting.

1. Loosen the locknut (B) on the pressure regulating valve, and back the adjusting screw or knob (A) out a few turns by turning it in a counterclockwise (CCW) direction. This will *decrease* the setting to a lower than desired pressure.
2. The pump must be completely connected electrically and hydraulically. Start the pump.
3. Slowly turn the adjusting screw or knob (A) in a clockwise (CW) direction. This gradually *increases* the pressure setting. When the desired pressure is reached, lock the adjusting screw (A) in position by tightening the locknut (B). Shut off the pump.

IMPORTANT:

- The pressure range is from 1,000 to 10,000 PSI (70 to 700 BAR) depending on the pump model.
- The pressure switch must be set at a higher pressure than working range to prevent shut down during adjustment.

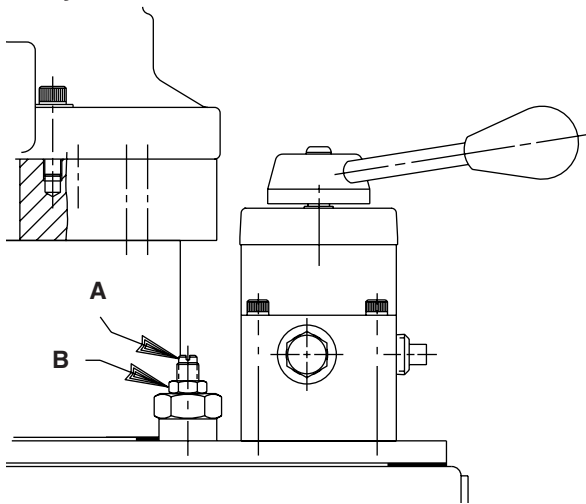
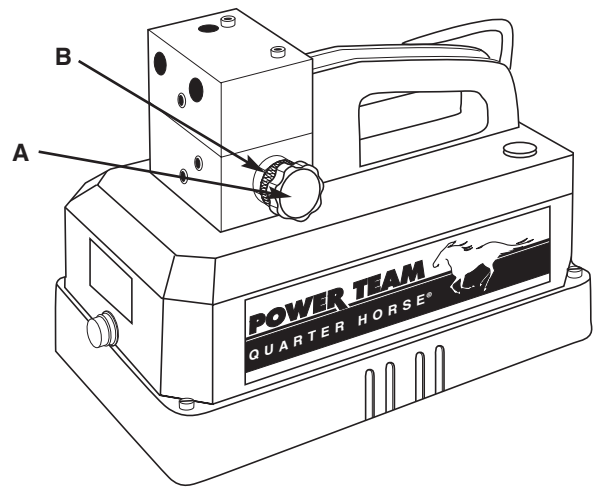

Figure 6



Adjusting The Pressure Switch

Generally, the pressure switch should be used with the pressure regulating valve. A pressure switch can be used *alone* for operating electrical devices such as motors, solenoids, relays, etc., which are located elsewhere in the circuit. Refer to Figure 7.

1. Loosen the locknut (B) on the pressure switch, and turn adjusting screw (A) in a clockwise (CW) direction. This *increases* the pressure setting to a higher than desired pressure.
2. Adjust the pressure regulating valve to the desired pressure setting. Refer to the section titled "Adjusting The Pressure Regulating Valve".
3. With the pump running and bypassing fluid at the desired pressure, slowly turn the pressure switch adjusting screw (A) in a counterclockwise (CCW) direction, *decreasing* the pressure switch setting until the pump motor shuts off. Then lock the adjusting screw (A) in position by tightening the locknut (B).
4. Release pressure. Run the pump to check the pressure setting and cut-out of the motor. If may be necessary to make a second adjustment.

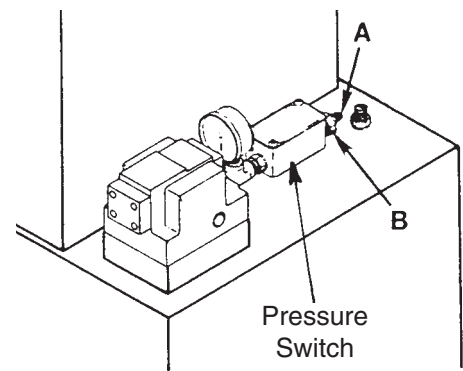

Figure 7

NOTE: When the pressure switch setting is reached, the motor will shut off. However, the inertia of the motor continues to deliver fluid for a brief period. The pressure regulating valve bypasses this surplus hydraulic fluid, preventing it from going into the system. As a result, the pressure differential can be held to approximately 300 PSI (21 BAR).

PREVENTIVE MAINTENANCE



WARNING: To help prevent personal injury,

- Disconnect the pump from the power supply before performing maintenance or repair procedures.
- Repairs and maintenance are to be performed in a dust-free area by a qualified technician.

Checking The Hydraulic Fluid And Filling The Reservoir (Except Bladder Type, See Below)

The hydraulic fluid level should be checked after initial set-up and after each ten hours of use.

1. Thoroughly clean the area around the filler cap with a clean cloth to prevent contamination of the hydraulic fluid.
2. Cylinder(s) must be fully retracted and the power supply disconnected.
3. Remove the filler cap and insert a clean funnel with filter. Fill to proper level as instructed in "Filling The Pump Reservoir Or Bladder" under Set-up Instructions.
4. Replace filler cap.
5. The frequency of fluid changes will depend upon the general working conditions, severity of use, and overall cleanliness and care given the pump. Three hundred hours of use under general shop conditions is considered a standard change interval. Drain, clean, and refill the reservoir with a high grade hydraulic fluid.

Checking The Hydraulic Fluid And Filling The Bladder

The hydraulic fluid level should be checked after initial set-up and after each ten hours of use.

1. Thoroughly clean the area around the filler cap with a clean cloth to prevent contamination of the hydraulic fluid.
2. Cylinder(s) must be fully retracted and the power supply disconnected. Position the pump with the filler plug in the up (or vertical) position.
3. Remove the filler cap and insert a clean funnel with filter. Fill the bladder completely full with a high grade hydraulic fluid.
4. Replace filler cap. **IMPORTANT: Tighten filler cap 1/2 - 1 turn after o-ring contacts sealing surface. Overtightening can cause pump damage on bladder equipped pumps.**
5. The frequency of fluid changes will depend upon the general working conditions, severity of use, and overall cleanliness and care given the pump. Three hundred hours of use under general shop conditions is considered a standard change interval. Drain, clean, and refill the reservoir with a high grade hydraulic fluid.

Maintenance Cleaning

IMPORTANT: Never use a high pressure washer to clean hydraulic components!

1. Keep the pump's outer surface as free from dirt as possible.
2. Seal all unused couplers with thread protectors.
3. Keep all hose connections free of dirt and grime.
4. The breather-hole in the filler cap must be clean and unobstructed at all times.
5. Equipment connected to the pump must be kept clean.
6. Use a high grade hydraulic fluid in this pump. Change as recommended (every 300 hours). Some conditions may require the use of different viscosity hydraulic fluids.

Lubrication (Air Driven Motor Only)

If the pump is operated on a continuous duty cycle or a maximum speeds for extended periods, an automatic air line oiler should be installed in the air inlet line as close to the pumping unit as possible. Set the unit to feed 1-3 drops of oil per minute (one drop for every 65 CFM [1,8 M³/min.] of air) into the system, or refer to the pump manufacturer's instructions. Use SAE No. 10 oil.

Engine Oil (Gas Engine Only)

Change engine oil as recommended for four stroke engines.

Mix the correct oil into fuel in proper ratio as recommended for two stroke engines.

Reservoir Vent Air Filter (Optional for all pumps except PR10 series)

1. Remove the filler cap, and insert either the 45° fitting or the straight fitting. Fasten o-ring end of fitting into pump.
2. If the 45° fitting is used, place the rubber spacer (included) on the top threaded portion.
Then thread the air filter on and hand tighten.
3. If the straight fitting is used, thread the air filter on and hand tighten.

PREVENTIVE MAINTENANCE CONTINUED -

Draining And Cleaning The Reservoir (Except Bladder Type, See Below)

IMPORTANT: Clean the pump exterior before the pump interior is removed from the reservoir.

1. Remove the screws fastening the motor and pump assembly to the reservoir. **IMPORTANT: Do not damage the gasket or pump filter or pressure regulating valves when lifting the pump and motor off the reservoir.**
2. Clean the inside of the reservoir and clean the filter.
3. Place the pump and motor assembly back onto the reservoir, and secure with machine screws.
4. Fill the reservoir with a clean, high grade hydraulic fluid (refer to "Filling The Pump Reservoir Or Bladder" under Set-up Instructions for proper fluid level for your pump).

Draining And Cleaning The Bladder

IMPORTANT: Clean the area around the filler hole to prevent contamination of the hydraulic fluid.

1. Remove the filler plug and drain hydraulic fluid completely.
2. Fill bladder half full with clean hydraulic fluid. Flush bladder with clean fluid and drain. **IMPORTANT: Never use solvents to clean the bladder! Never disassemble the bladder from the pump!**
3. Fill the bladder completely full with a clean, high grade hydraulic fluid.

TROUBLE-SHOOTING GUIDE



WARNING

- To help prevent personal injury, any repair work or trouble-shooting must be done by qualified personnel familiar with this equipment.
- Use the proper gauges and equipment when trouble-shooting.

NOTE:

- For a detailed parts list or to locate a Power Team Authorized Hydraulic Service Center contact your nearest Power Team facility.
- It is best to check for system leaks by using a hand pump and applying pressure to the suspect area. Watch for leaking fluid and follow it back to its source. *Never* use your hand or other body parts to check for a possible leak.

PROBLEM	CAUSE	SOLUTION
Electric motor does not run	<ol style="list-style-type: none"> 1. Pump not turned ON. 2. Unit is not plugged in. 3. No voltage supply. 	<ol style="list-style-type: none"> 1. Set switch to "ON" position. 2. Plug in unit. 3. Check line voltage. Check reset button or fuse on power panel.
WARNING: To help prevent personal injury, disconnect power supply before removing cover. Any electrical work should be performed by a qualified electrician.	<ol style="list-style-type: none"> 4. Pressure switch not set properly. 5. Broken lead wire or defective power cord plug. 6. Overheated motor has caused overcurrent protection to disengage. 	<ol style="list-style-type: none"> 4. Refer to "Adjusting The Pressure Switch" information under "Adjusting The Pressure Regulating Controls" section. 5. Contact a Power Team Authorized Hydraulic Service Center. 6. Wait for motor to cool before restarting.
Electric motor will not shut off.	<ol style="list-style-type: none"> 1. Defective motor controls. 	<ol style="list-style-type: none"> 1. Disconnect from power supply and contact a Power Team Authorized Hyd. Service Center.
Electric motor stalls, surges, overheats or will not start under a load.	<ol style="list-style-type: none"> 1. Low voltage or electrical cord size too small. 	<ol style="list-style-type: none"> 1. Refer to the "Electric Pump" information under "Pump Operation" section.

TROUBLE-SHOOTING GUIDE CONTINUED -

PROBLEM	CAUSE	SOLUTION
Electrical overload protector keeps tripping.	1. Wired incorrectly.	1. See Service Bulletin #9903PT at the end of this document.
Pump is not delivering fluid or delivers only enough fluid to advance cylinder(s) partially or erratically.	1. Fluid level too low. 2. Quick disconnect couplings are not completely coupled. 3. Air in system. 4. Cold fluid or fluid too viscous. 5. Reservoir capacity is too small for the size of cylinder(s) used. 6. Three phase motor rotating in wrong direction. 7. PR10 series pump not connected to correct 12 VDC polarity. 8. Vacuum in reservoir.	1. Fill reservoir or bladder according to directions "Filling The Pump Reservoir Or Bladder" under "Set-up Instructions" section 2. Check quick-disconnect couplings to cylinders to ensure that they are completely coupled. Occasionally couplers have to be replaced because the ball check does not stay open due to wear. 3. Refer to the section titled "Bleeding the System" under "Set-up Instructions" section. 4. Hydraulic fluid is of a higher viscosity than necessary. Change to a lighter fluid. 5. Use smaller cylinder(s) or larger reservoir. 6. Refer to electrical schematic on motor. 7. Connect to correct 12 VDC polarity. 8. Check for plugged vent in filler plug.
Pump builds pressure but cannot maintain pressure.	1. External leaks. 2. Internal or external leakage on hydraulic cylinder. 3. Leaking control valve or check valve.	1. Seal leaking pipe fittings with pipe sealant. Replace leaking pipes or hoses. 2. Remove the cylinder from pump. If the pump builds and maintains full pressure, the cylinder is defective. Contact a Power Team Authorized Hydraulic Service Center. 3. Contact a Power Team Authorized Hyd. Service Center.
Pump will not build full pressure.	1. Faulty pressure gauge. 2. Check for external leakage. 3. Improperly adjusted external pressure regulator setting. 4. Internal or external leakage on hydraulic cylinder.	1. Calibrate gauge. 2. Seal faulty fittings with sealant. Replace leaking pipes or hoses. 3. Refer to "Adjusting The Pressure Regulator Valve" information under "Adjusting the Pressure Regulating Controls" section. 4. Remove the cylinder from the pump. If the pump builds full pressure, the cylinder is defective. Contact a Power Team Authorized Hyd. Service Center.

TROUBLE-SHOOTING GUIDE CONTINUED -

PROBLEM	CAUSE	SOLUTION
Pump will not build full pressure. (continued)	5. Inadequate power supply. 6. Leaking control valve or defective pump.	5. Refer to "Air Pump" or "Electric Pump" information under "Pump Operation" section. 6. Contact a Power Team Authorized Hydraulic Service Center.
Cylinder(s) will not retract or extend.	1. Quick disconnect couplings are not completely coupled.  DANGER: A double-acting cylinder or ram must have <u>both</u> hoses and all couplers securely connected to both ports. If one of the two ports is restricted or becomes disconnected, pressure will build and the cylinder, hose or coupler can burst, possibly causing serious injury or death. 2. Broken return spring in spring return cylinder or seals blown in double-acting cylinder.	1. Check quick disconnect coupling to cylinders to ensure that they are completely coupled. Occasionally couplers have to be replaced because the ball check does not stay open due to wear. 2. Contact a Power Team Authorized Hydraulic Service Center.
Pump delivers excess oil pressure.	1. Faulty pressure gauge. 2. Relief valve not properly set.	1. Calibrate gauge. 2. Contact a Power Team Authorized Hydraulic Service Center.

POWER TEAM FACILITIES



 **UNITED STATES**
 SPX Corporation-Fluid Power
 5885 11th Street
 Rockford, IL 61109-3699
 USA
 Telephone: 1-815-874-5556
 FAX: 1-815-874-7853

Cust. Service/Order Entry
 Tel: 1-800-541-1418
 FAX: 1-800-288-7031
E-mail:
 info@fluidpower.spx.com

Technical Services
 Tel: 1-800-477-8326
 FAX: 1-800-765-8326

 **CHINA**
 212 Jiang Ning Road
 CATIC Tower 23C
 Shanghai 200041, China
 Tel: 86 (21) 5289 5858
 FAX: 86 (21) 5289 5866
E-mail:
 info.asia@fluidpower.spx.com

 **FAR EAST**
 7 Gul Circle
 Singapore 629563
 Singapore
 Tel: (65) 6265-3343
 FAX: (65) 6265-6646
E-mail:
 info.asia@fluidpower.spx.com

 **EUROPE**
 Albert Thijsstraat 12
 6471 WX Eyselshoven
 Netherlands
 Tel: 31 (45) 5678877
 FAX: 31 (45) 5678878
E-mail
 info.europe@fluidpower.spx.com