

DETAIL A

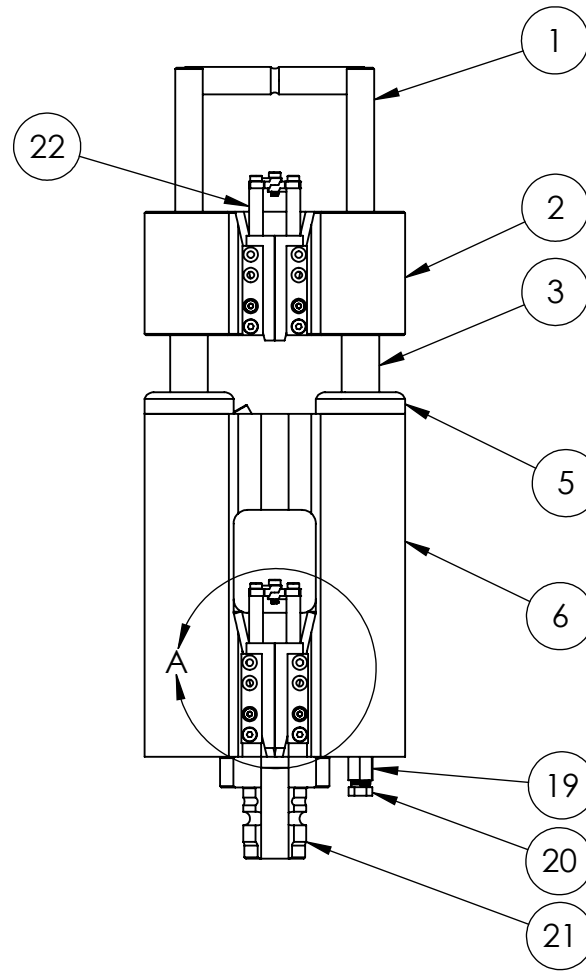

FRONT

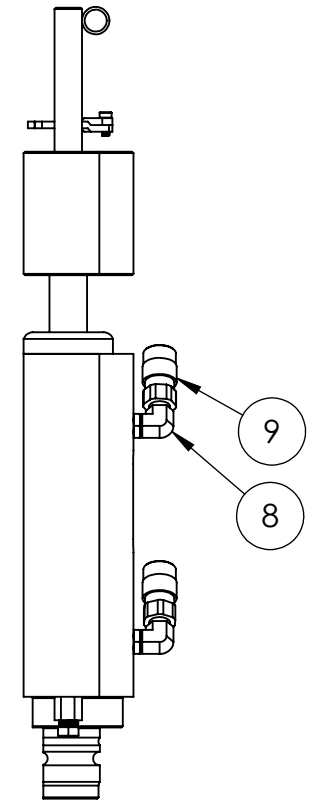

LEFT SIDE

ITEM NO.	PART NUMBER	DESCRIPTION	QTY.
1	TT-HAND-HXMD	Handle, Medium	1
2	TT-BRDG-30UP	X30 Pulling Bridge	1
3	TT-SHFT-30	X30 Shaft	2
4	TT-PSTN-3025	X30 Piston	2
5	TT-GLND-30	X30 Gland	2
6	TT-BRDG-30UR	X30 Retaining Bridge	1
7	TT-GCPS-INTP	Gripper Cover Plate (C20/X20/X30/M50)	4
8	TT-HFIT-LSAE	90-Deg Elbow (#8 ORBM, 3/8 NPTF)	2
9	TT-HFIT-PHPF	Parker Quick Disconnect (Female)	2
10	TT-FSNR-FB4500C	Handle Bolt (X20/X30/M50)	2
11	TT-FNSR-BA500H	Shoulder Screw (Cover Plate)	4
12	TT-FSNR-BA750F	Cover Plate Screw	4
13	TT-FSNR-EB1500C	Nose Bolt	4
14	TT-SEAL-30PS	X30 Piston Seal	2
15	TT-SEAL-30GS	X30 Gland Seal	2
16	TT-SEAL-30GB	X30 Gland Back-Up Seal	2
17	TT-SEAL-30SS	X30/C25 Shaft Seal	2
18	TT-SEAL-30SW	X30/C25 Shaft Wiper	2
19	TT-HFIT-SAEO	Reducer (#8 ORBM, 3/8 NPTF)	1
20	TT-PBOC-7500	7500 PSI Pressure Valve	1
21	TT-NOSE-LSFB	Locking Steel Four-Bolt Nose	1
22	TTA-GA-34M	3/4" M Gripper Assembly	2

UNLESS OTHERWISE SPECIFIED:

DIMENSIONS ARE IN INCHES
TOLERANCES:
TWO PLACE DECIMAL ±.01
THREE PLACE DECIMAL ±.005

PROPRIETARY AND CONFIDENTIAL

THE INFORMATION CONTAINED IN THIS DRAWING IS THE SOLE PROPERTY OF TRIC TOOLS. ANY REPRODUCTION IN PART OR AS A WHOLE WITHOUT THE WRITTEN PERMISSION OF TRIC TOOLS IS PROHIBITED.

DRAWN	NAME	DATE
	RMD	3/2015

COMMENTS:

ITEMS NOT SHOWN:

4, 10, 13, 14, 15,
16, 17, AND 18

TRIC Tools, Inc.

TITLE:

X30

SIZE	DWG. NO.	REV
A	TTP-HPLS-30	F

NOT TO SCALE

SHEET 1 OF 3

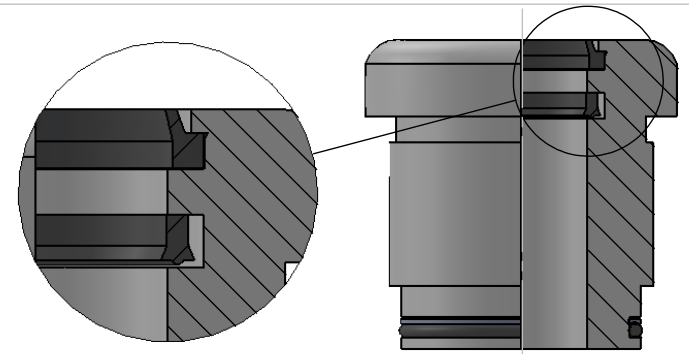
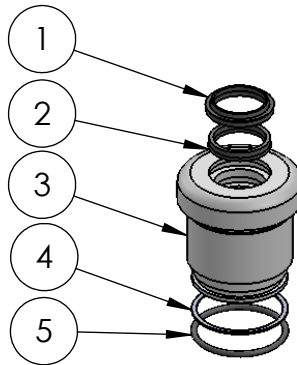
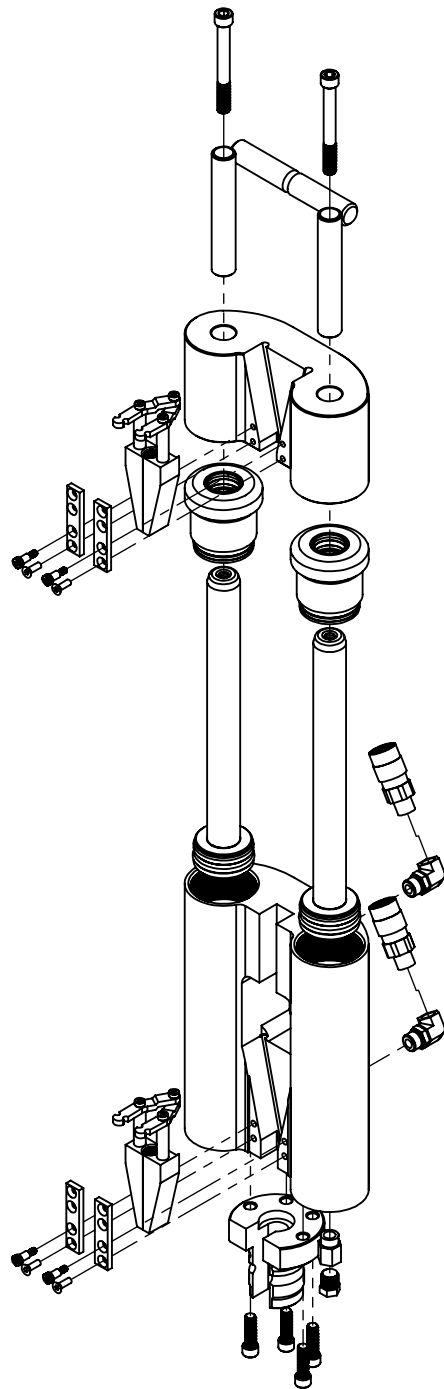

ITEM NO.	PART NUMBER	DESCRIPTION	QTY.
1	TT-SEAL-30SW	X30/C25 Shaft Wiper	1
2	TT-SEAL-30SS	X30/C25 Shaft Seal	1
3	TT-GLND-30	X30 Gland	1
4	TT-SEAL-30GB	X30 Gland Back-Up Seal	1
5	TT-SEAL-30GS	X30 Gland Seal	1

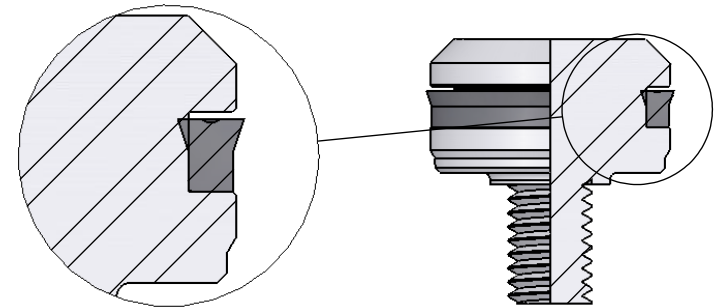
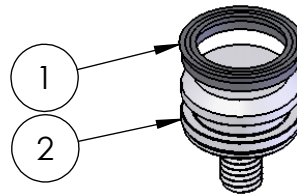

ITEM NO.	PART NUMBER	DESCRIPTION	QTY.
1	TT-SEAL-30PS	X30 Piston Seal	1
2	TT-PSTN-3025	X30 Piston	1

UNLESS OTHERWISE SPECIFIED:

DIMENSIONS ARE IN INCHES
TOLERANCES:
TWO PLACE DECIMAL ±.01
THREE PLACE DECIMAL ±.005

PROPRIETARY AND CONFIDENTIAL

THE INFORMATION CONTAINED IN THIS DRAWING IS THE SOLE PROPERTY OF TRIC TOOLS. ANY REPRODUCTION IN PART OR AS A WHOLE WITHOUT THE WRITTEN PERMISSION OF TRIC TOOLS IS PROHIBITED.

NAME DATE

RMD 3/2015

DRAWN
COMMENTS:

TRIC Tools, Inc.

TITLE:

X30

SIZE	DWG. NO.	REV
A	TTP-HPLS-30	F

SCALE: 1:8

SHEET 2 OF 3

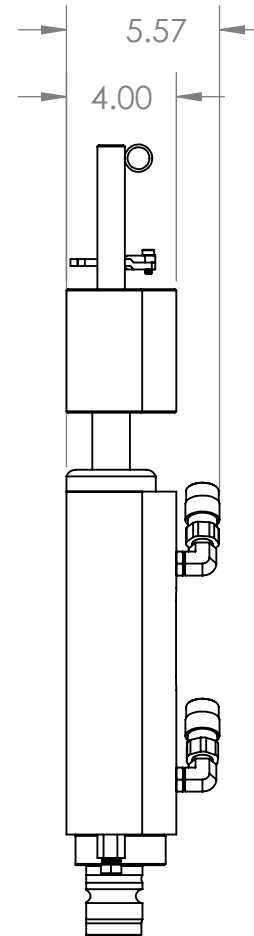
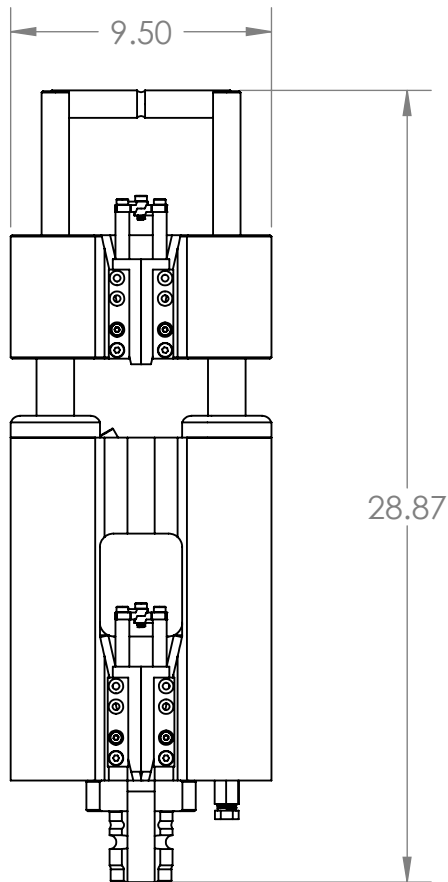

SHIP WEIGHT: 85 LBS.

UNLESS OTHERWISE SPECIFIED: DIMENSIONS ARE IN INCHES TOLERANCES: TWO PLACE DECIMAL ±.25 THREE PLACE DECIMAL ±.005 PROPRIETARY AND CONFIDENTIAL THE INFORMATION CONTAINED IN THIS DRAWING IS THE SOLE PROPERTY OF TRIC TOOLS. ANY REPRODUCTION IN PART OR AS A WHOLE WITHOUT THE WRITTEN PERMISSION OF TRIC TOOLS IS PROHIBITED.	NAME	DATE	TRIC Tools, Inc.	
	DRAWN	RMD		
	COMMENTS:		TITLE: X30	
	SIZE	DWG. NO.	REV	
	A	TTP-HPLS-30	F	
SCALE: 1:7			SHEET 3 OF 3	